

QuikStix™ Drywall Ceilings Locking Pocket Mains (Patent Pending): Reduces time and labor installing drywall ceilings in tight plenum conditions.

- ✓ Uptight clip allows installation in 1-1/2" to 5-1/2" plenums
- ✓ Locking Pocket Main has the same characteristics as a Strongback
- ✓ Locking Pocket Main allows uptight installation because installed at same level as ShortSpan tees
- ✓ ShortSpan Tees can span up to 7' without verticle support (16" o.c.)
- ✓ Locking Angle Mold eliminates measuring, marking and screwing at perimeters

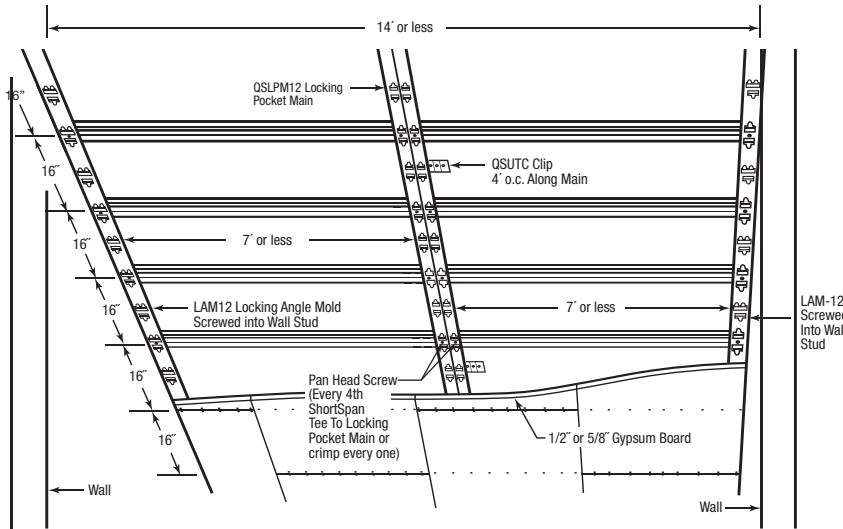

Membrane Load Values

Max Load in LBS/SF (L/240)	Max Load in LBS/SF (L/240)
- Locking Pocket Mains 7' o.c. - Uptight Clips 4' o.c. along mains - ShortSpan Tees 16" o.c.	- Locking Pocket Mains 6' o.c. - Uptight Clips 3' o.c. along mains - ShortSpan Tees 16" o.c.
2.80 LBS/SF (1 layer of 5/8" drywall)	4.87 LBS/SF (Up to 2 layers of 5/8" drywall)

Note: 5/8" drywall weighs 2.4 lbs/SF or less
1/2" drywall weighs 2.0 lbs/SF or less
Fixtures should be independently supported
*For other combinations; consult TechLine at 1-877-Armstrong

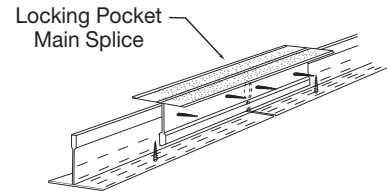

Installation Notes:

1. Vertical Supports to structure should be either QuikStix Uptight Clips or stiff legs using scrap metal. Wire is **NOT** recommended for hanging this system.
2. ShortSpan tees must be cut within 1/8" of vertical leg of the Locking Angle Moldings and Locking Pocket Mains.
3. To engage ShortSpan tees into Lockng Pockets: insert right hand flange of tee into long pocket first and allow left flange to clear short pocket and rest flat. Slide tee to the left to engage in short pocket (audible click).

QuikStix™ Drywall Ceiling Components

Item#	Length/ Item Description	Face Dimensions	Profile Height	Simple Span Uniform Load at L/240 (lbs./LF)	Perspective
QSLPM12	12' Locking Pocket Main (Locking Tabs 8" o.c.)	1-1/2"	1-1/2"	Vertical supports @ 4' o.c. - 22.37 Vertical supports @ 3' o.c. - 47.3	
S7708 S7710 S7712 S7714	8' Tee 10' Tee 12' Tee 14' Tee	1-1/2" 1-1/2" 1-1/2" 1-1/2"	1-1/2" 1-1/2" 1-1/2" 1-1/2"	All Items: 4ft. Span - 23.32 5ft. Span - 12.11 6ft. Span - 6.18	
LAM-12	12' Locking Angle Mold (Locking tabs 8" o.c.)	1-1/4" x 1-1/4"	—	—	
QSUTC	QuikStix Uptight Clip (Pre-drilled Screw Holes)	1-3/4" Wide	1-1/2" x 4-1/2"	—	

Note: All components are available with G90 hot dipped galvanized coating. Just add G90 suffix to end of item #.

Uptight Clip (QSUTC): Saves time in tight plenum areas and is adjustable to uneven surfaces

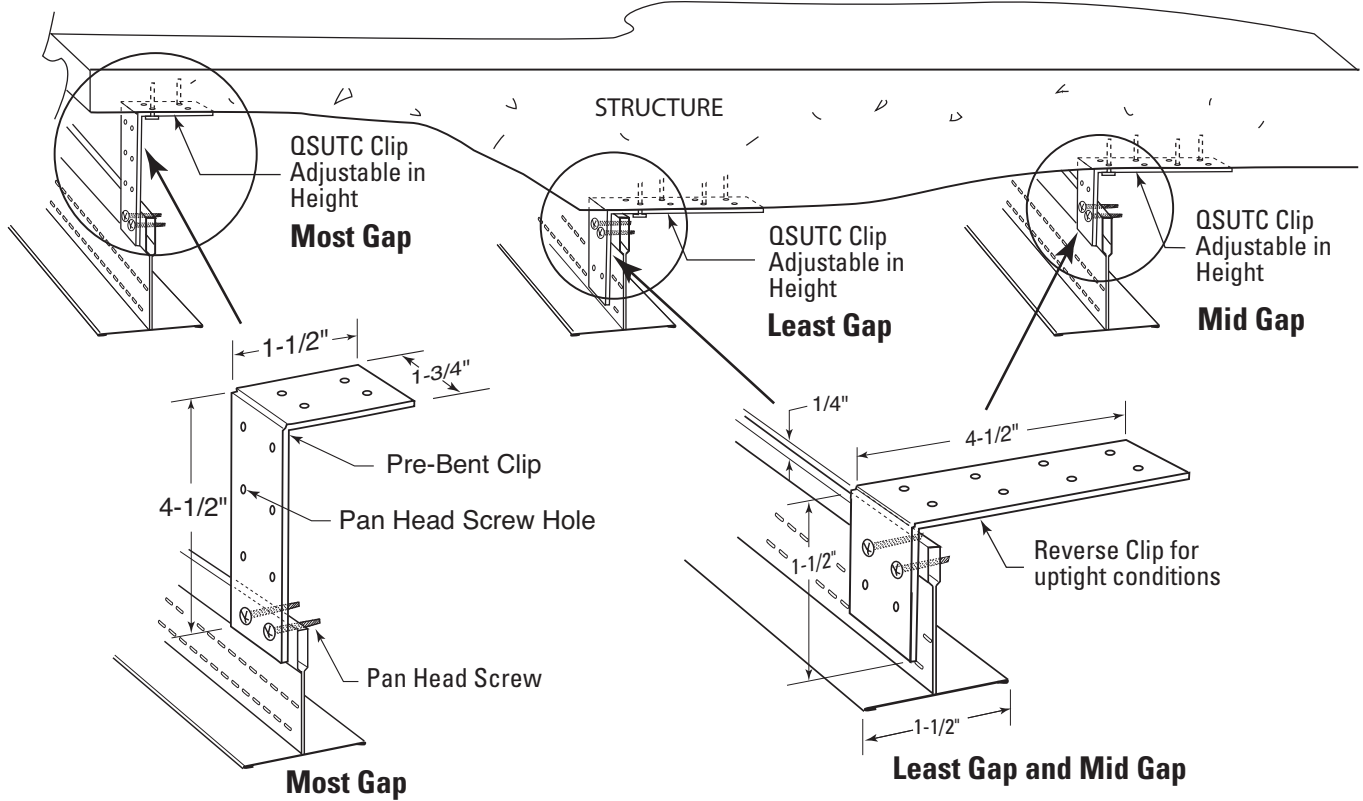

Locking Pocket Mains Help With Corridor Transitions

